

1

2

3

4

5

6

A

A

B

B

C

C

D

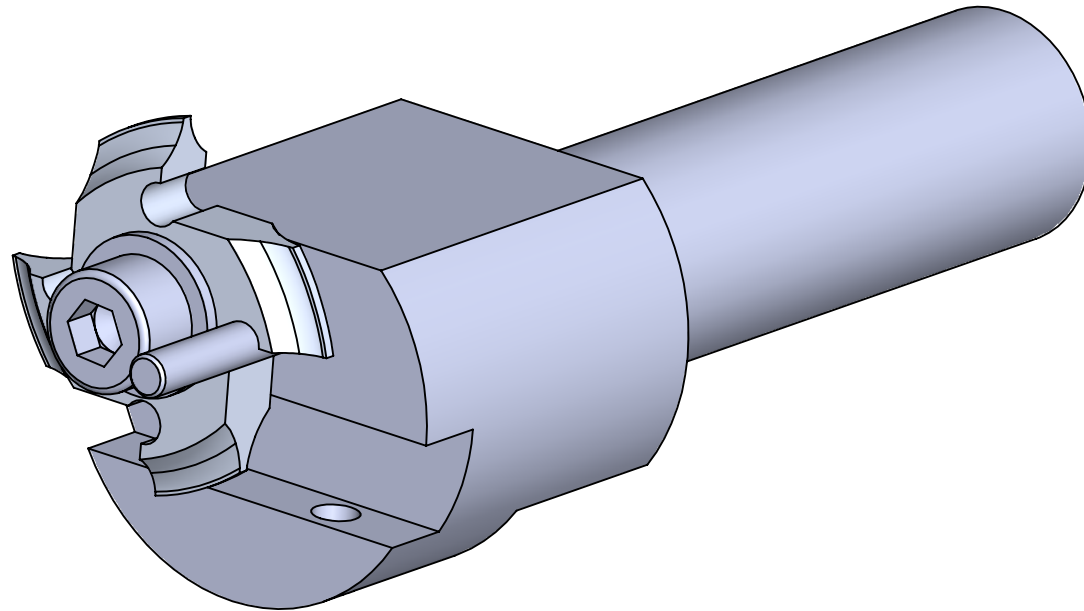

UNLESS OTHERWISE SPECIFIED:
DIMENSIONS ARE IN INCHES

UNLESS OTHERWISE SPECIFIED, TOLERANCES:
LINEAR: DIMENSIONS UNDER 5/8 INCH ± 0.012
DIMENSIONS 5/8 INCH AND OVER ± 0.04
ANGULAR: $\pm 0.5^\circ$

REMOVE ALL BURRS AND SHARP EDGES
0.02 RADIUS OR CHAMFER MAX

MATERIAL: MILD STEEL, O1 TOOL STEEL

TITLE:

CUTTER ARBOR ASSEM.
(MULTI TOOTH CONFIG)



CLICKSPRINGPROJECTS.COM

A4

1

2

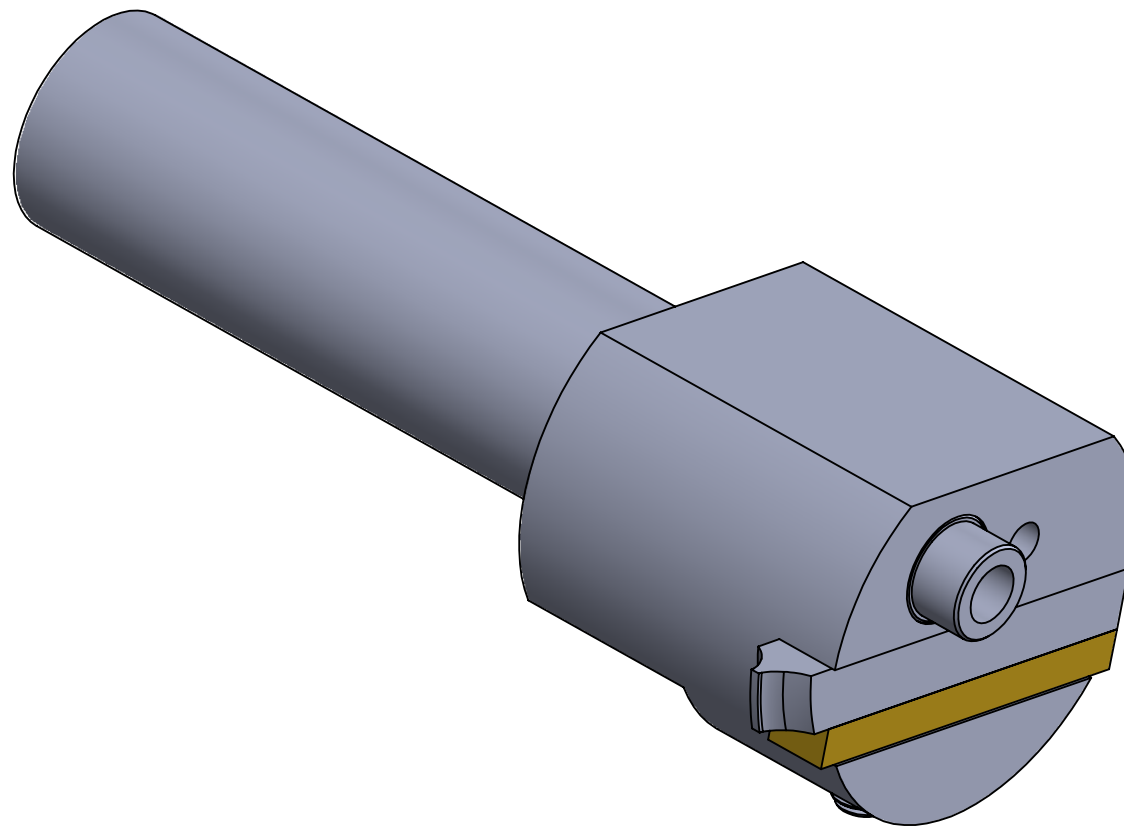

UNLESS OTHERWISE SPECIFIED:
DIMENSIONS ARE IN INCHES

UNLESS OTHERWISE SPECIFIED, TOLERANCES:
LINEAR: DIMENSIONS UNDER 5/8 INCH ± 0.012
DIMENSIONS 5/8 INCH AND OVER ± 0.04
ANGULAR: $\pm 0.5^\circ$

REMOVE ALL BURRS AND SHARP EDGES
0.02 RADIUS OR CHAMFER MAX

MATERIAL: MILD STEEL, O1 TOOL STEEL

TITLE:

CUTTER ARBOR ASSEM.
(FLYCUTTER CONFIG)



CLICKSPRINGPROJECTS.COM

A4

ITEM NO.	PART NUMBER	QTY.
1	Blank Cutting Arbor	1
2	Boss Insert	1
3	M5 Cap Screw	1
4	Washer	1
5	Cutter	1
6	Flycutter	1
7	Packing Strip	1
8	Indexing Pin	1
9	Cutter Blank	1

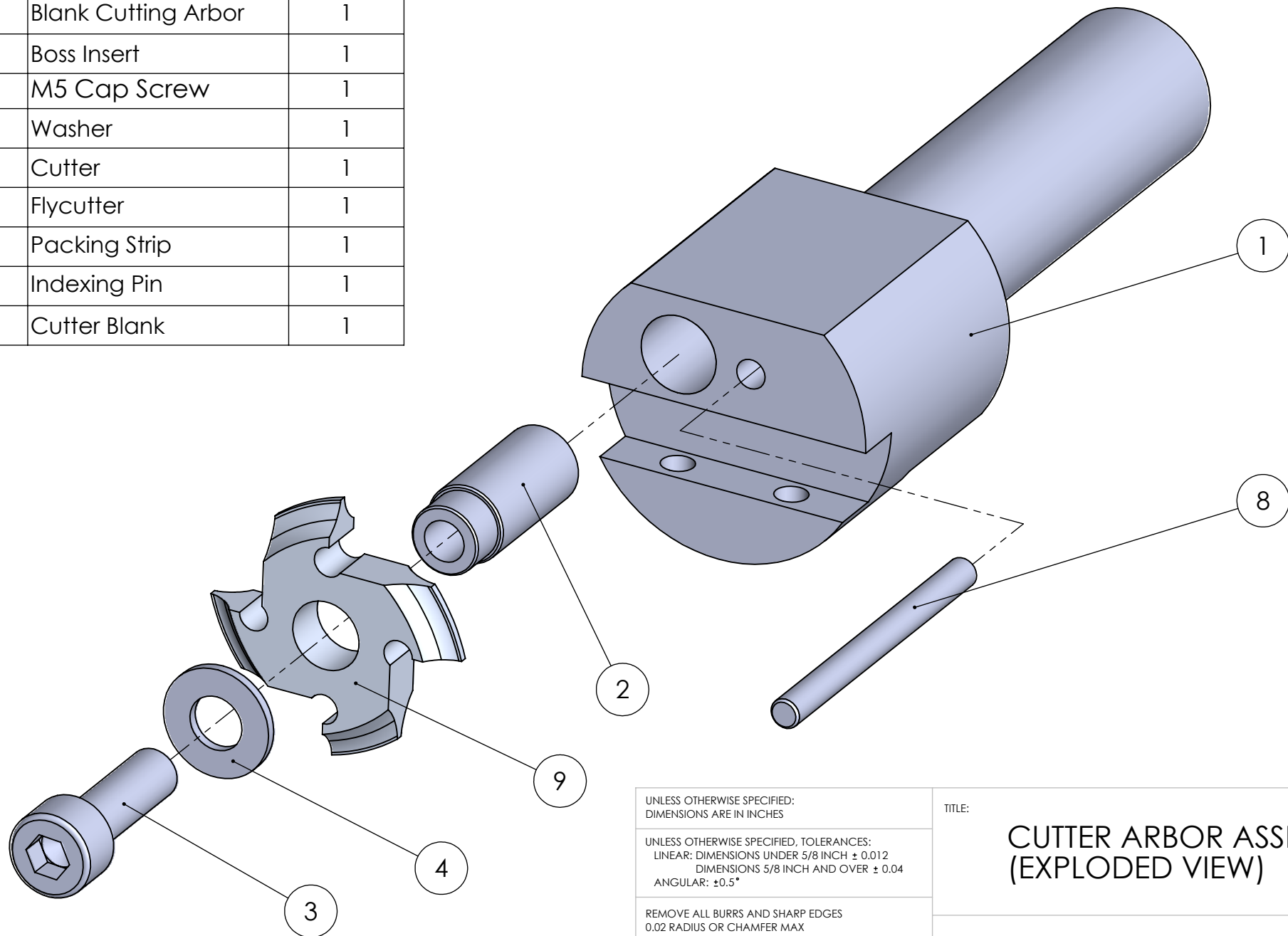

UNLESS OTHERWISE SPECIFIED:
DIMENSIONS ARE IN INCHES

UNLESS OTHERWISE SPECIFIED, TOLERANCES:
LINEAR: DIMENSIONS UNDER 5/8 INCH ± 0.012
DIMENSIONS 5/8 INCH AND OVER ± 0.04
ANGULAR: $\pm 0.5^\circ$

REMOVE ALL BURRS AND SHARP EDGES
0.02 RADIUS OR CHAMFER MAX

MATERIAL: MILD STEEL, O1 TOOL STEEL

TITLE:
**CUTTER ARBOR ASSEM.
(EXPLODED VIEW)**

CLICKSPRINGPROJECTS.COM

A4

1

2

3

4

5

6

A

A

B

B

C

C

D

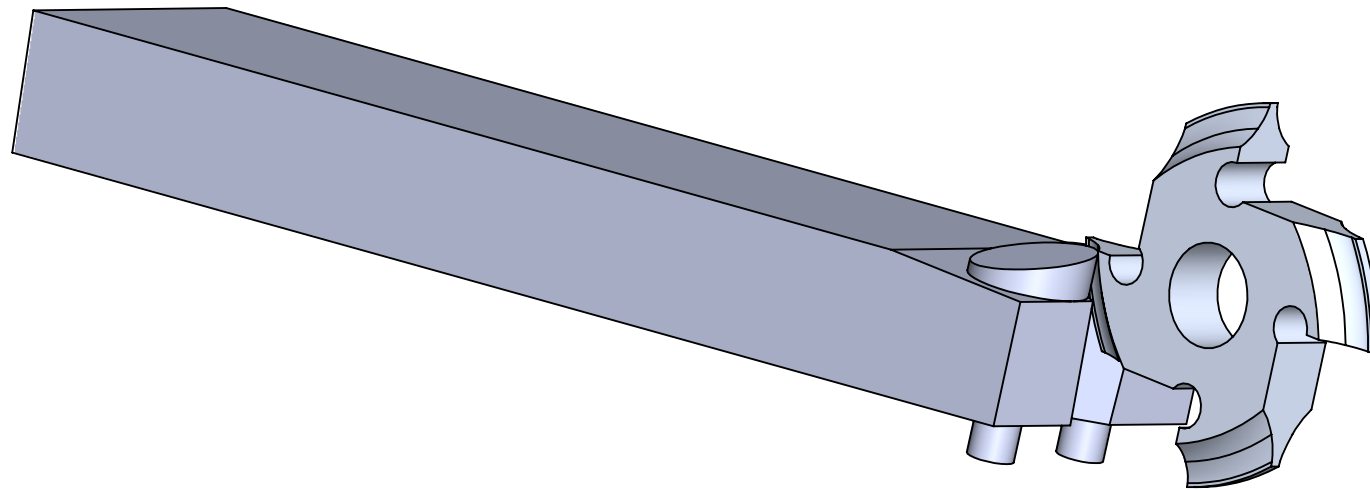

UNLESS OTHERWISE SPECIFIED:
DIMENSIONS ARE IN INCHES

UNLESS OTHERWISE SPECIFIED, TOLERANCES:
LINEAR: DIMENSIONS UNDER 5/8 INCH ± 0.012
DIMENSIONS 5/8 INCH AND OVER ± 0.04
ANGULAR: $\pm 0.5^\circ$

REMOVE ALL BURRS AND SHARP EDGES
0.02 RADIUS OR CHAMFER MAX

MATERIAL: MILD STEEL, O1 TOOL STEEL

TITLE:

BUTTON CUTTER



CLICKSPRINGPROJECTS.COM

A4

1

2

ITEM NO.	PART NUMBER	QTY.
1	Button Cutter Shank	1
2	Button Cutter	2
3	Cutter Blank	1

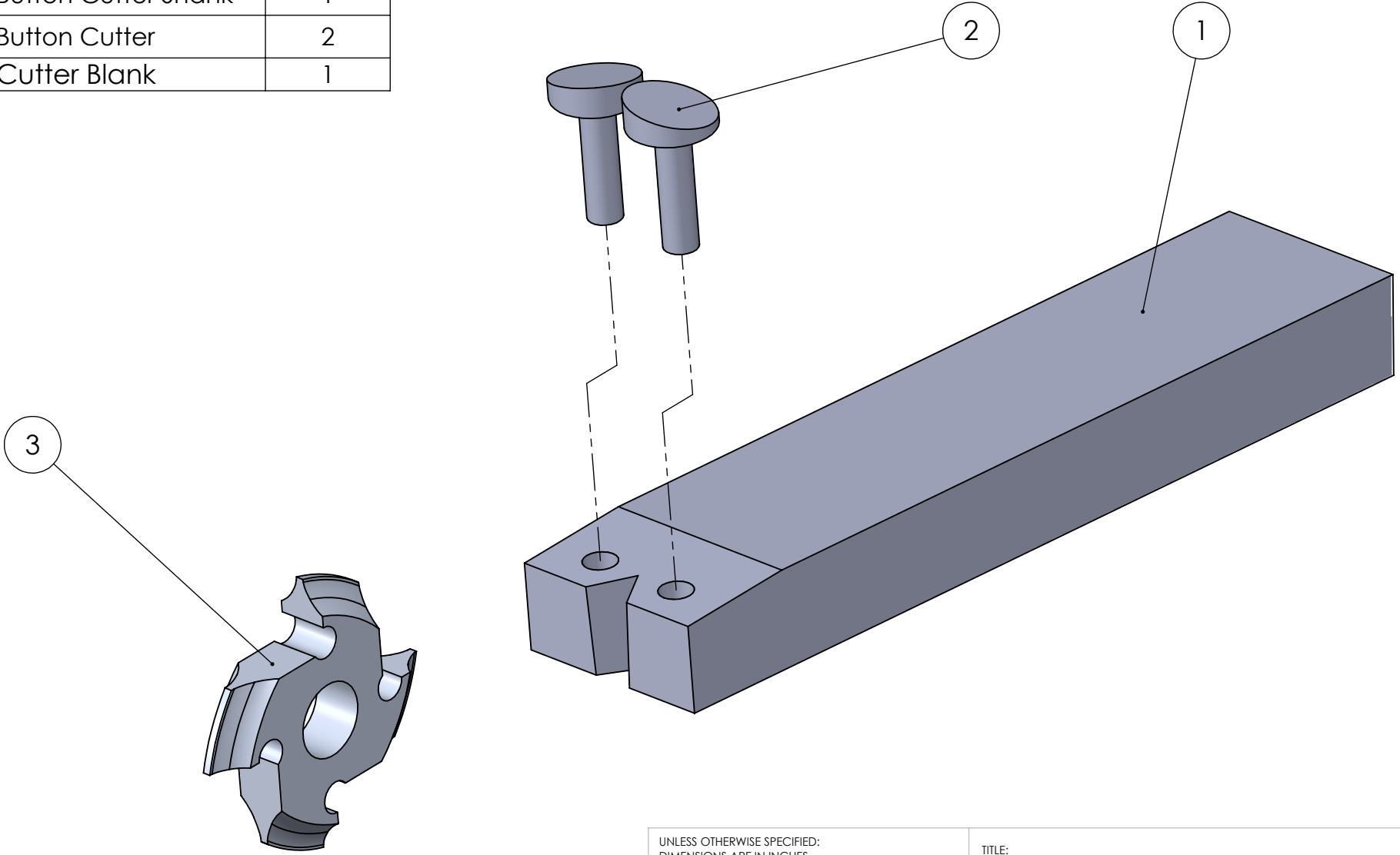

UNLESS OTHERWISE SPECIFIED:
DIMENSIONS ARE IN INCHES

UNLESS OTHERWISE SPECIFIED, TOLERANCES:
LINEAR: DIMENSIONS UNDER 5/8 INCH ± 0.012
DIMENSIONS 5/8 INCH AND OVER ± 0.04
ANGULAR: $\pm 0.5^\circ$

REMOVE ALL BURRS AND SHARP EDGES
0.02 RADIUS OR CHAMFER MAX

MATERIAL: MILD STEEL, O1 TOOL STEEL

TITLE:
**BUTTON CUTTER
(EXPLODED VIEW)**

CLICKSPRINGPROJECTS.COM



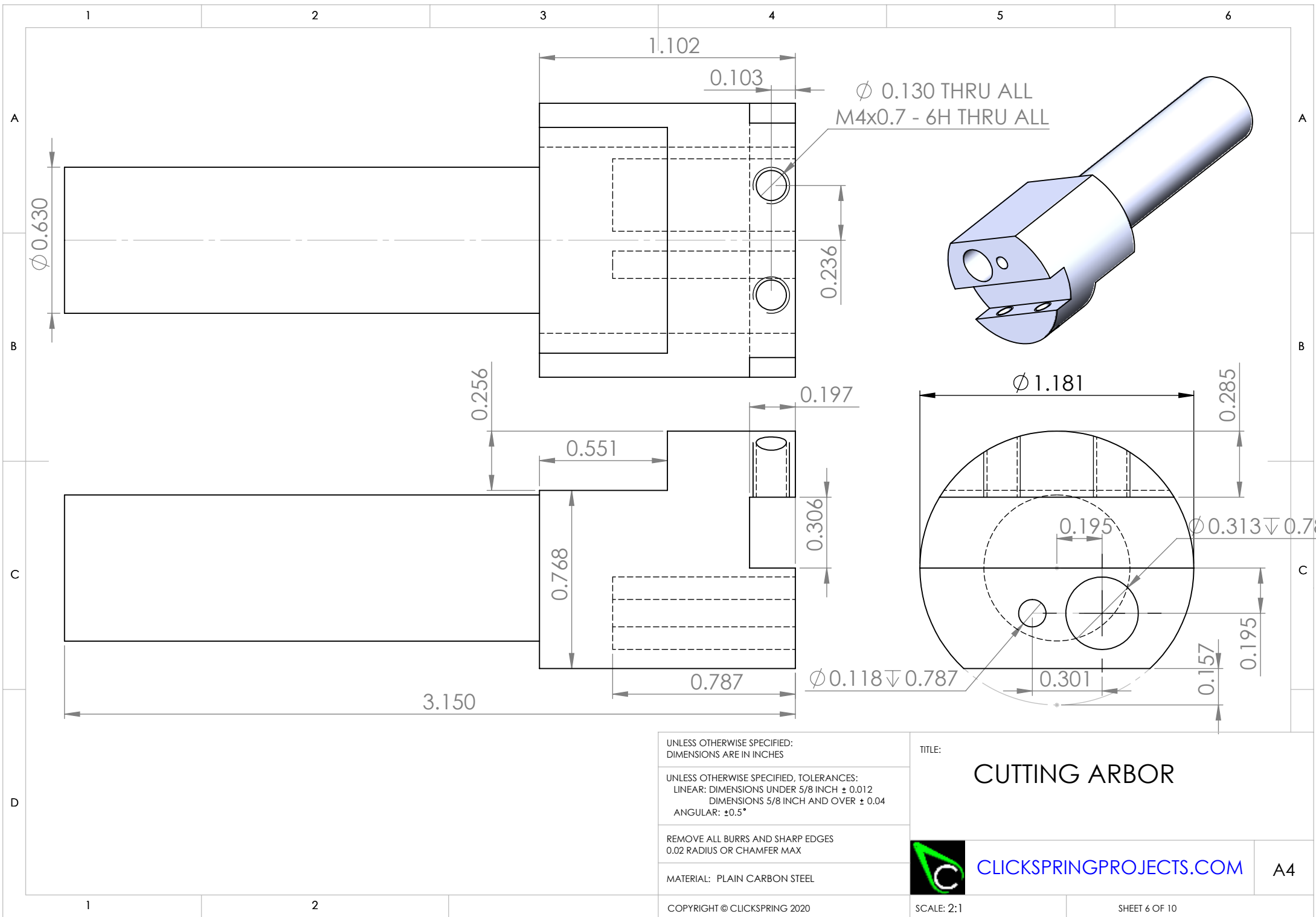

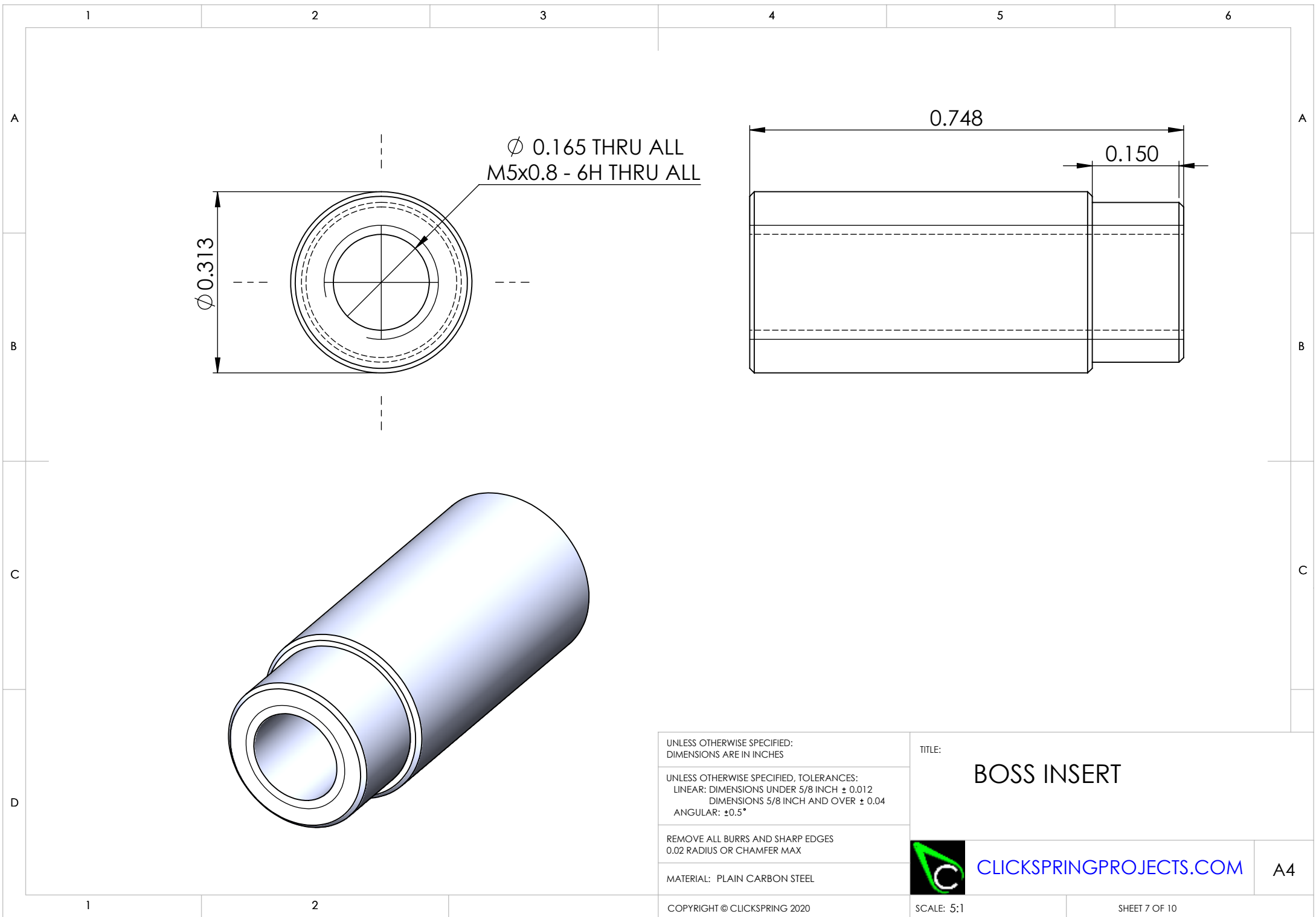

UNLESS OTHERWISE SPECIFIED:
DIMENSIONS ARE IN INCHES

UNLESS OTHERWISE SPECIFIED, TOLERANCES:
LINEAR: DIMENSIONS UNDER 5/8 INCH ± 0.012
DIMENSIONS 5/8 INCH AND OVER ± 0.04
ANGULAR: $\pm 0.5^\circ$

REMOVE ALL BURRS AND SHARP EDGES
0.02 RADIUS OR CHAMFER MAX

MATERIAL: PLAIN CARBON STEEL

TITLE: **BOSS INSERT**

 CLICKSPRINGPROJECTS.COM A4

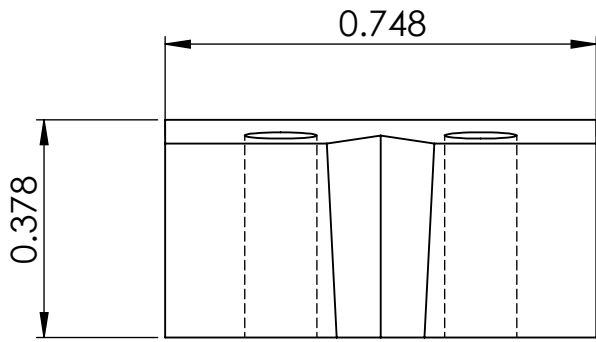
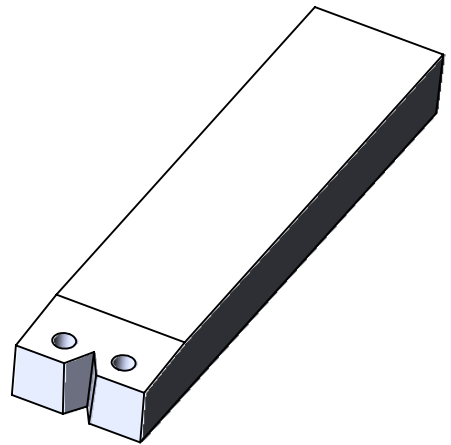

R0.063 THRU

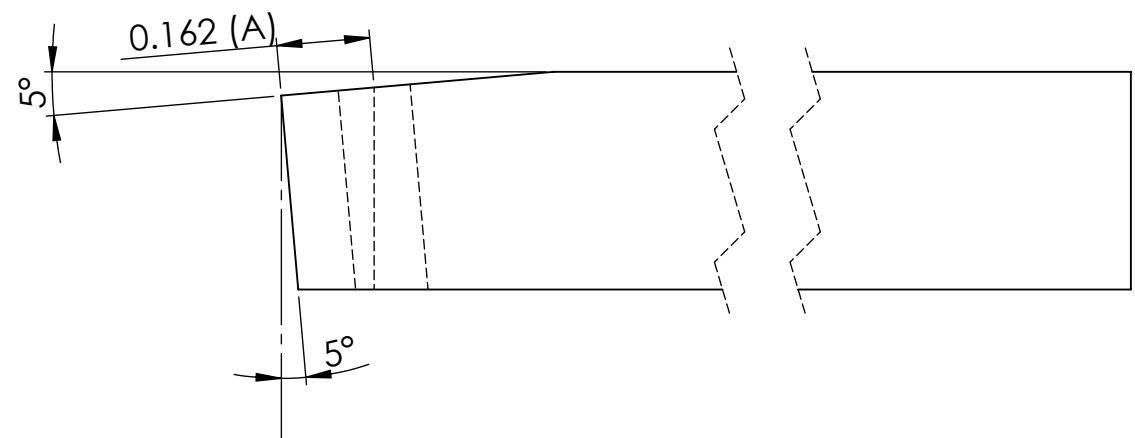
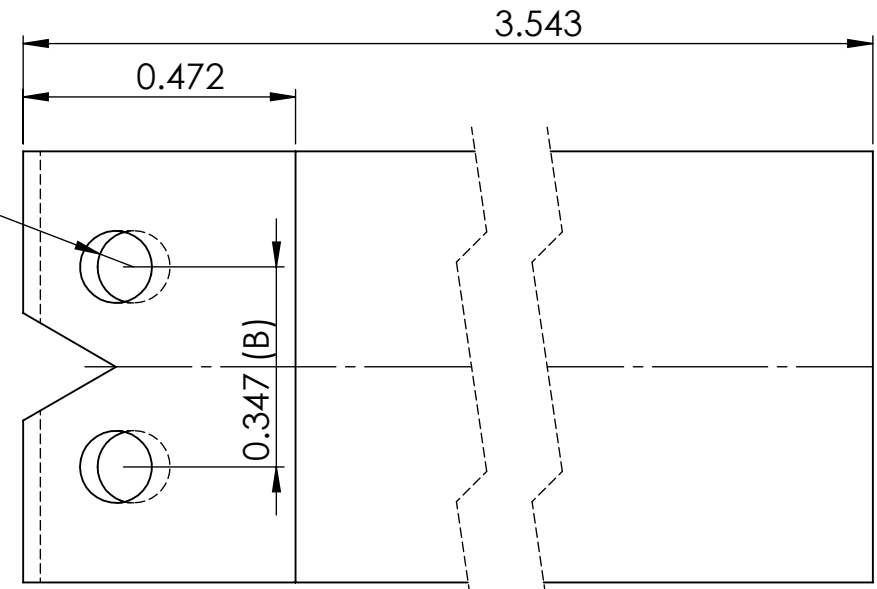

- NOTES, UNLESS OTHERWISE SPECIFIED
- DIMENSIONS A AND B NOMINAL:
 - A=0.5 X BUTTON DIAMETER
 - B=BUTTON CENTER DISTANCE
 - REFER CALCULATOR
 - OTHER DIMENSIONS ADJUST AS REQUIRED TO ACCOMMODATE LATHE CENTER HEIGHT LIMITATIONS

UNLESS OTHERWISE SPECIFIED:
DIMENSIONS ARE IN INCHES

UNLESS OTHERWISE SPECIFIED, TOLERANCES:
 LINEAR: DIMENSIONS UNDER 5/8 INCH ± 0.012
 DIMENSIONS 5/8 INCH AND OVER ± 0.04
 ANGULAR: ±0.5°

REMOVE ALL BURRS AND SHARP EDGES
0.02 RADIUS OR CHAMFER MAX

MATERIAL: PLAIN CARBON STEEL

TITLE:

BUTTON CUTTER SHANK



CLICKSPRINGPROJECTS.COM

A4

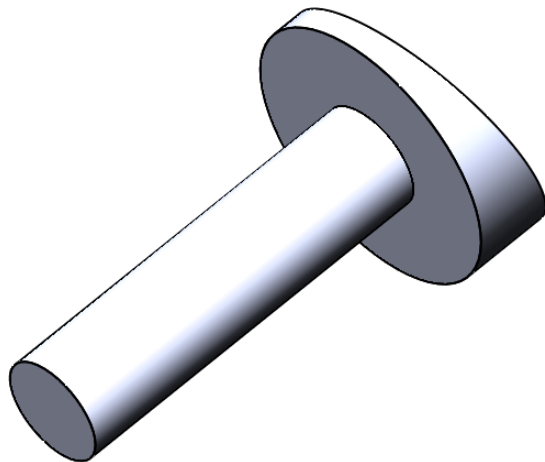
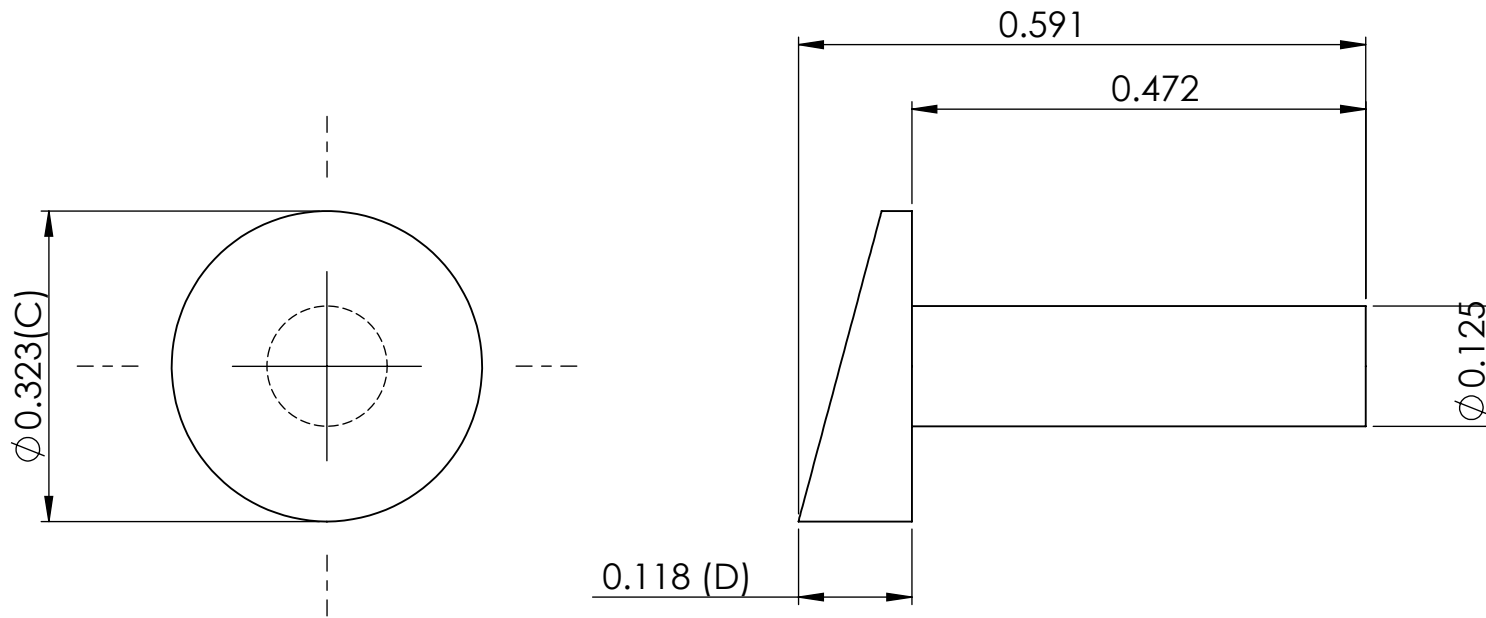

NOTES, UNLESS OTHERWISE SPECIFIED

- DIMENSIONS C AND D NOMINAL
 - C=BUTTON DIAMETER
 - REFER CALCULATOR
- D AND OTHER DIMENSIONS ADJUST AS REQUIRED TO ACCOMODATE LATHE CENTER HEIGHT LIMITATIONS

UNLESS OTHERWISE SPECIFIED:
DIMENSIONS ARE IN INCHES

UNLESS OTHERWISE SPECIFIED, TOLERANCES:
LINEAR: DIMENSIONS UNDER 5/8 INCH ± 0.012
DIMENSIONS 5/8 INCH AND OVER ± 0.04
ANGULAR: $\pm 0.5^\circ$

REMOVE ALL BURRS AND SHARP EDGES
0.02 RADIUS OR CHAMFER MAX

MATERIAL: O1 TOOL STEEL

TITLE:

BUTTON CUTTER



CLICKSPRINGPROJECTS.COM

A4

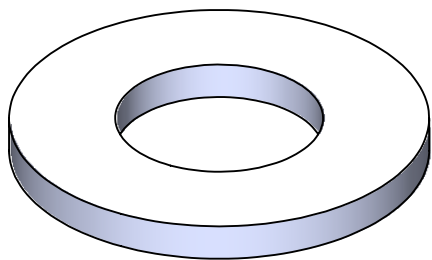
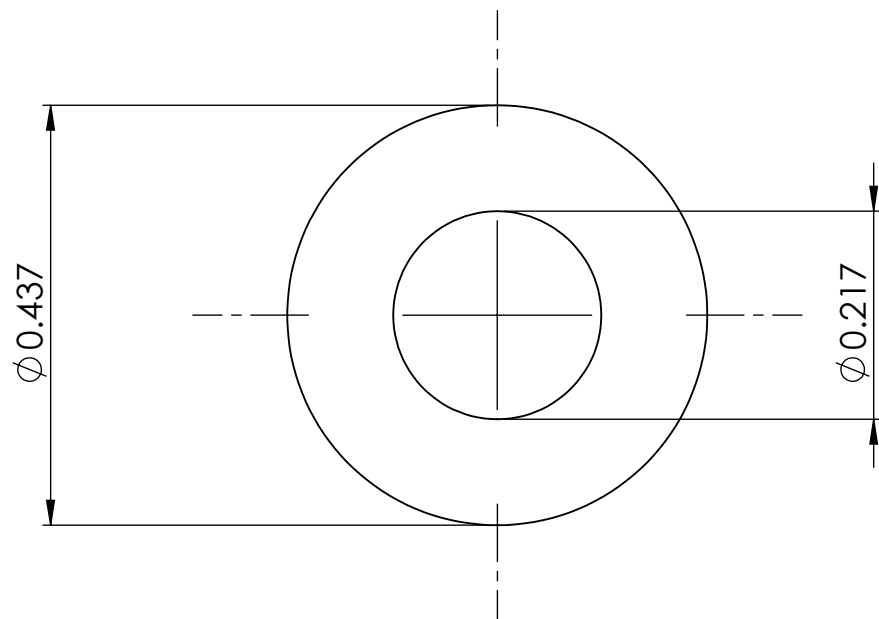

UNLESS OTHERWISE SPECIFIED:
DIMENSIONS ARE IN INCHES

UNLESS OTHERWISE SPECIFIED, TOLERANCES:
LINEAR: DIMENSIONS UNDER 5/8 INCH ± 0.012
DIMENSIONS 5/8 INCH AND OVER ± 0.04
ANGULAR: $\pm 0.5^\circ$

REMOVE ALL BURRS AND SHARP EDGES
0.02 RADIUS OR CHAMFER MAX

MATERIAL: PLAIN CARBON STEEL

TITLE:

WASHER



CLICKSPRINGPROJECTS.COM

A4